

# NeuroMaker Hand 2.0

Assembly Instruction

+

Quick Start Guide (Page 57)



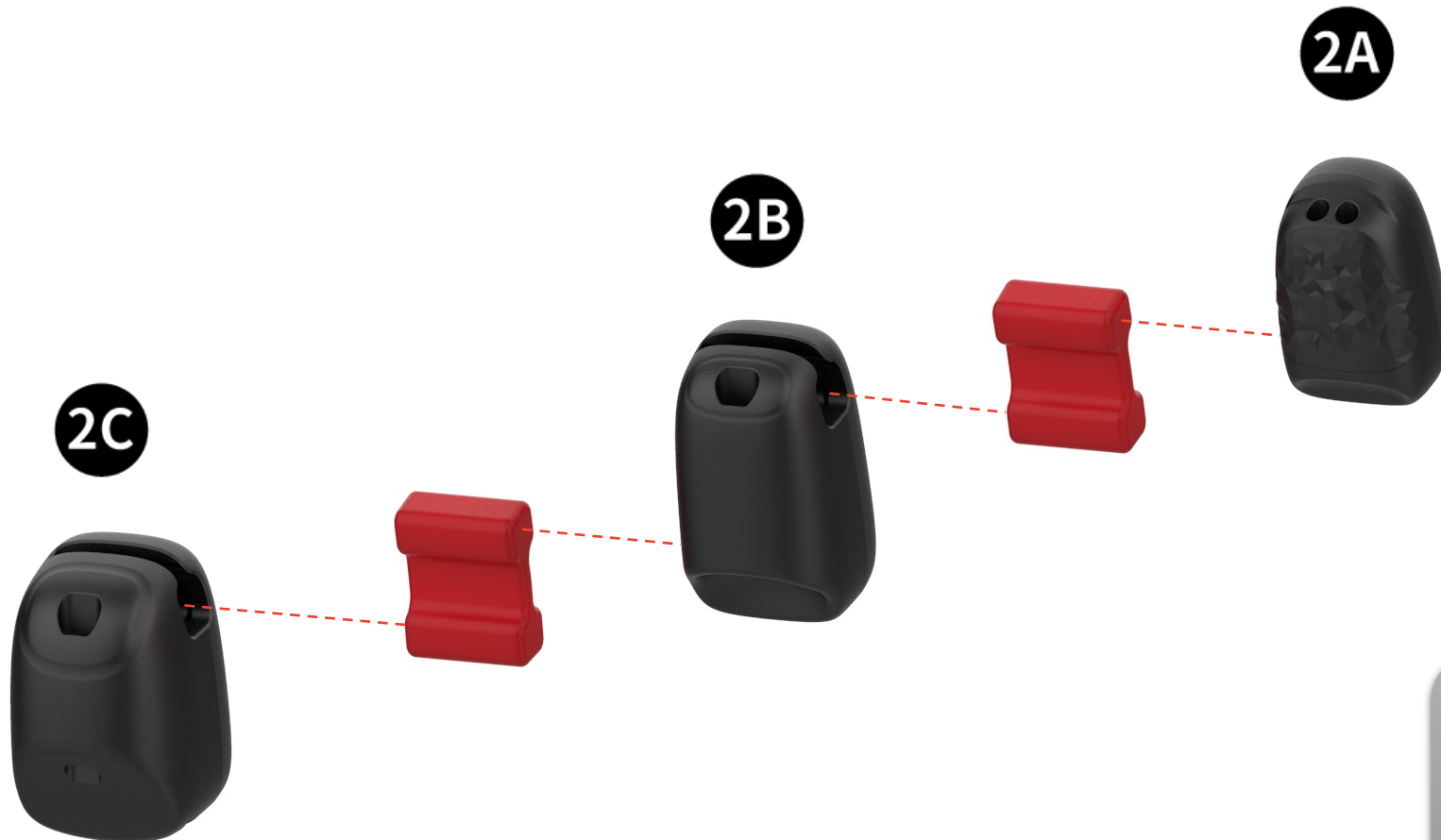

Assemble the index finger by sliding the **General Hinges** to the grooves on the finger segments.



Slide the index finger assembly to the left most slot on the wide hinge.

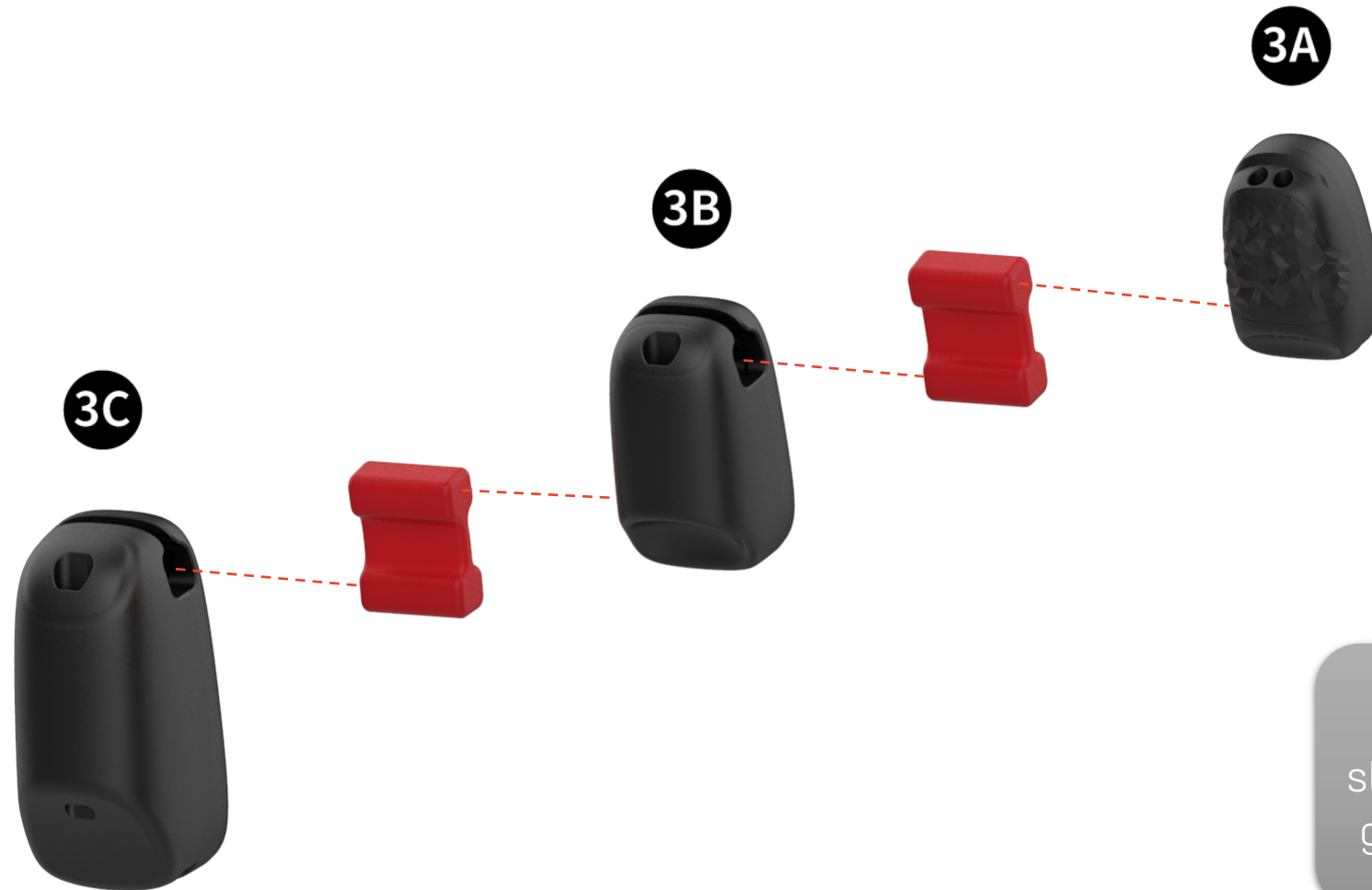

Assemble the middle finger by sliding the **General Hinges** to the grooves on the finger segments.



Slide the middle finger assembly to the slot on the wide hinge, next to the index finger.

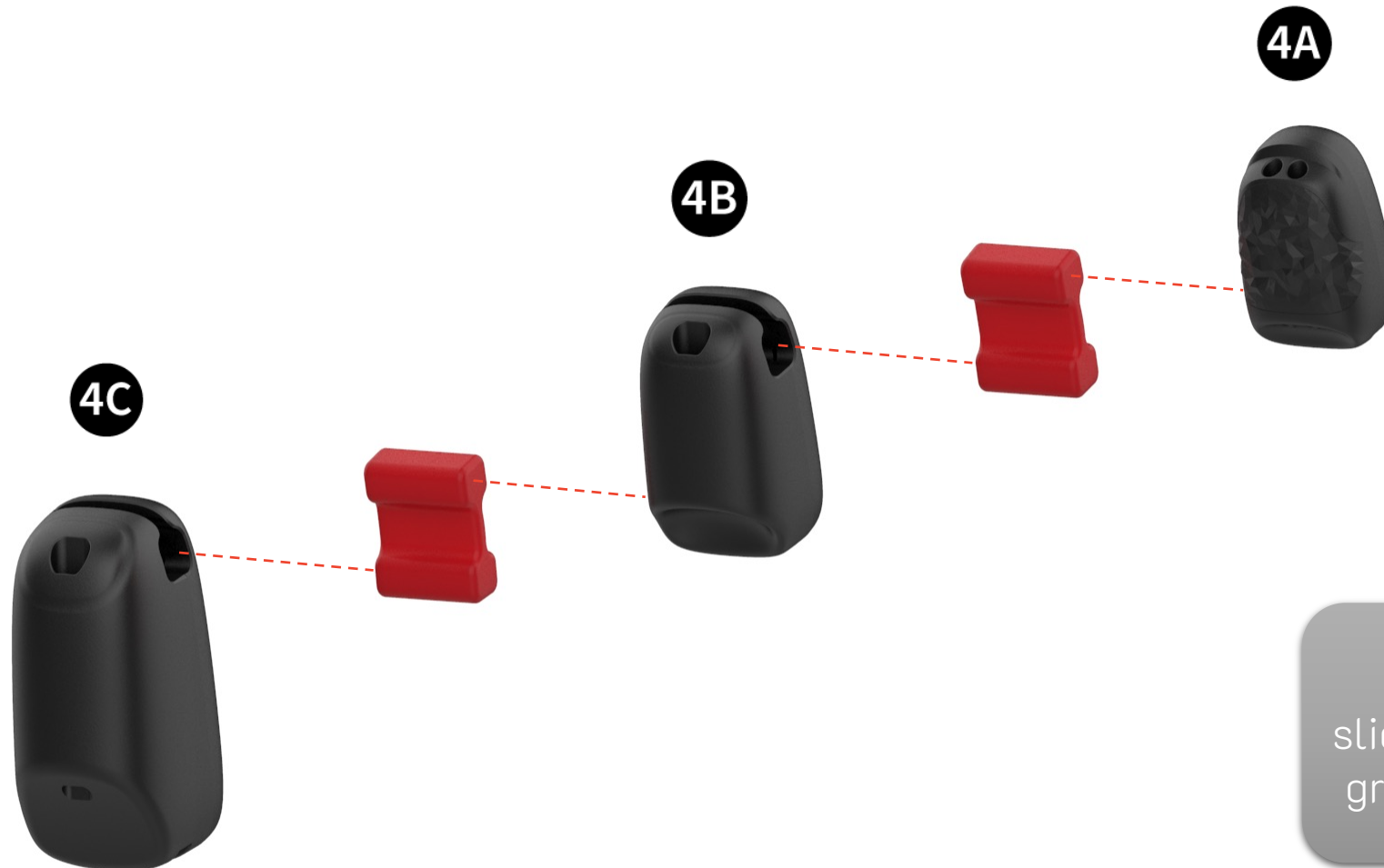

Assemble the ring finger by sliding the **General Hinges** to the grooves on the finger segments.



Slide the ring finger assembly to the slot on the wide hinge, next to the middle finger.

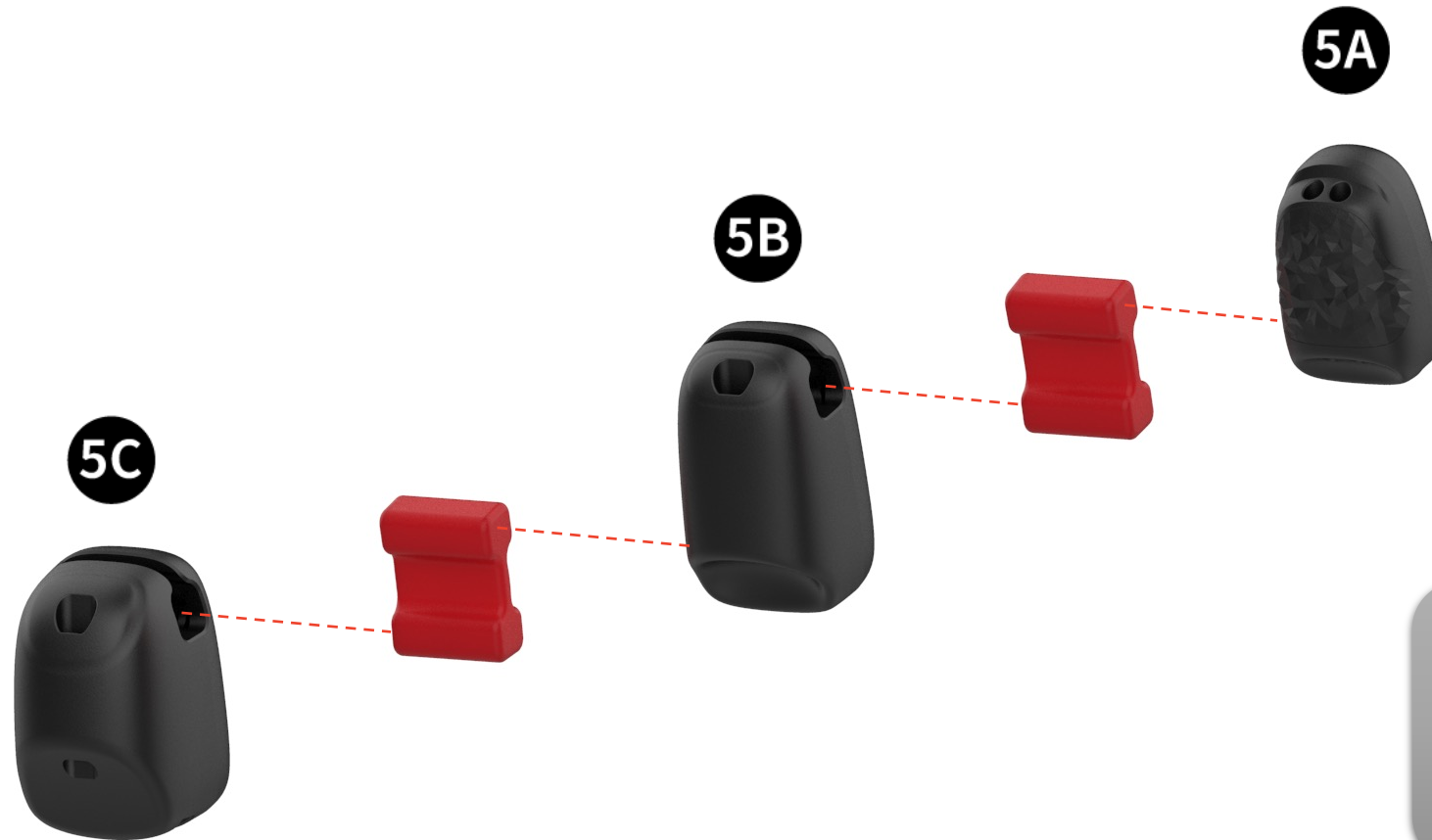

Assemble the little finger by sliding the **General Hinges** to the grooves on the finger segments.





Slide the little finger assembly to the remaining slot on the wide hinge, next to the ring finger.



Check the markings on the back side of the fingers and make sure they match this illustration.

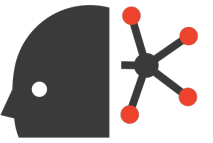

**NEUROMAKER**

Assemble the thumb by sliding the **General Hinge** between 1A and 1B, then sliding the **Thumb Hinge** under 1B.

1A



1B



Thumb Hinge



Thumb hinge should bend this way



Slide the thumb assembly to  
the slot on the thumb base.



Assemble the front palm and another thumb base. Manually hold the thumb base at the position indicated in the illustration on the right.





Slide the thumb assembly  
into the opening on the  
front palm.

 This slot needs to align



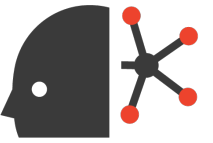

**NEUROMAKER**

Install and adjust the screw, allowing the thumb to be repositioned as shown in the illustration. **Ensure it's tight enough to prevent unintended rotation.**



Use screw type





Attach the entire finger assembly to the front palm.





**NEUROMAKER**



Step 1: Cut a piece of tendon wire with length equal to the span of your fully extended arms.

Step 2: Fold the wire in half to create two equal-length sections.

Step 3: Insert each end of the wire into the two slots at the top of the little finger assembly.

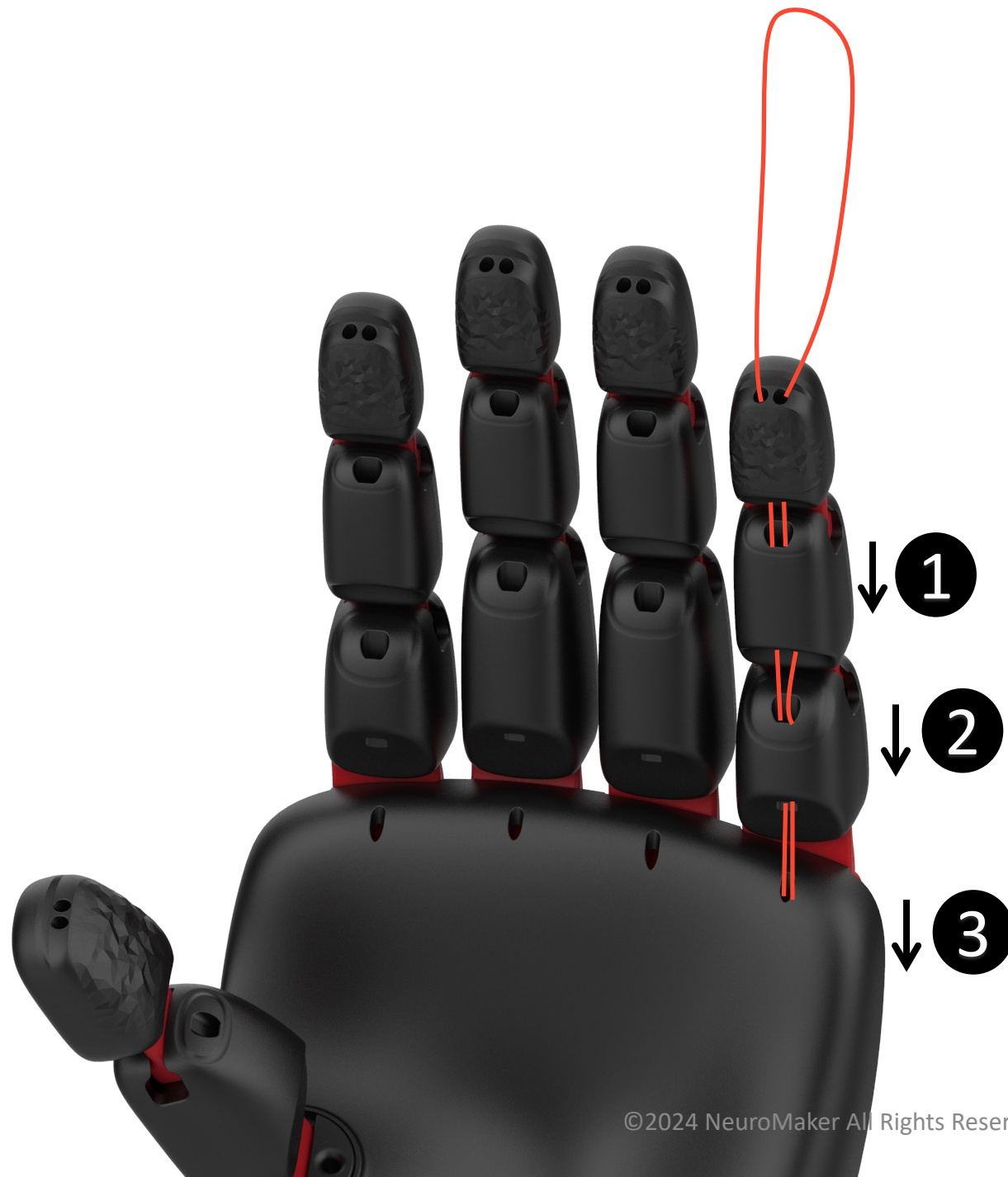

Step 1: Guide both ends of the tendon wire downwards through the top and middle sections of the finger.

Step 2: Continue threading both ends of the wire through the bottom section of the finger.

Step 3: Finally, insert both ends of the wire into the slot located on the palm.



Pull the tendon wire downwards to tighten it, as shown in the illustration.



Repeat the previous steps to install a tendon wire for the ring finger.



Repeat the previous steps to install tendon wires for the middle and index finger.

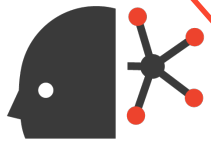

**NEUROMAKER**

Step 1: Cut a piece of tendon wire with length equal to the span of your fully extended arms.

Step 2: Fold the wire in half to create two equal-length sections.

Step 3: Insert each end of the wire into the two slots at the top of the thumb assembly.

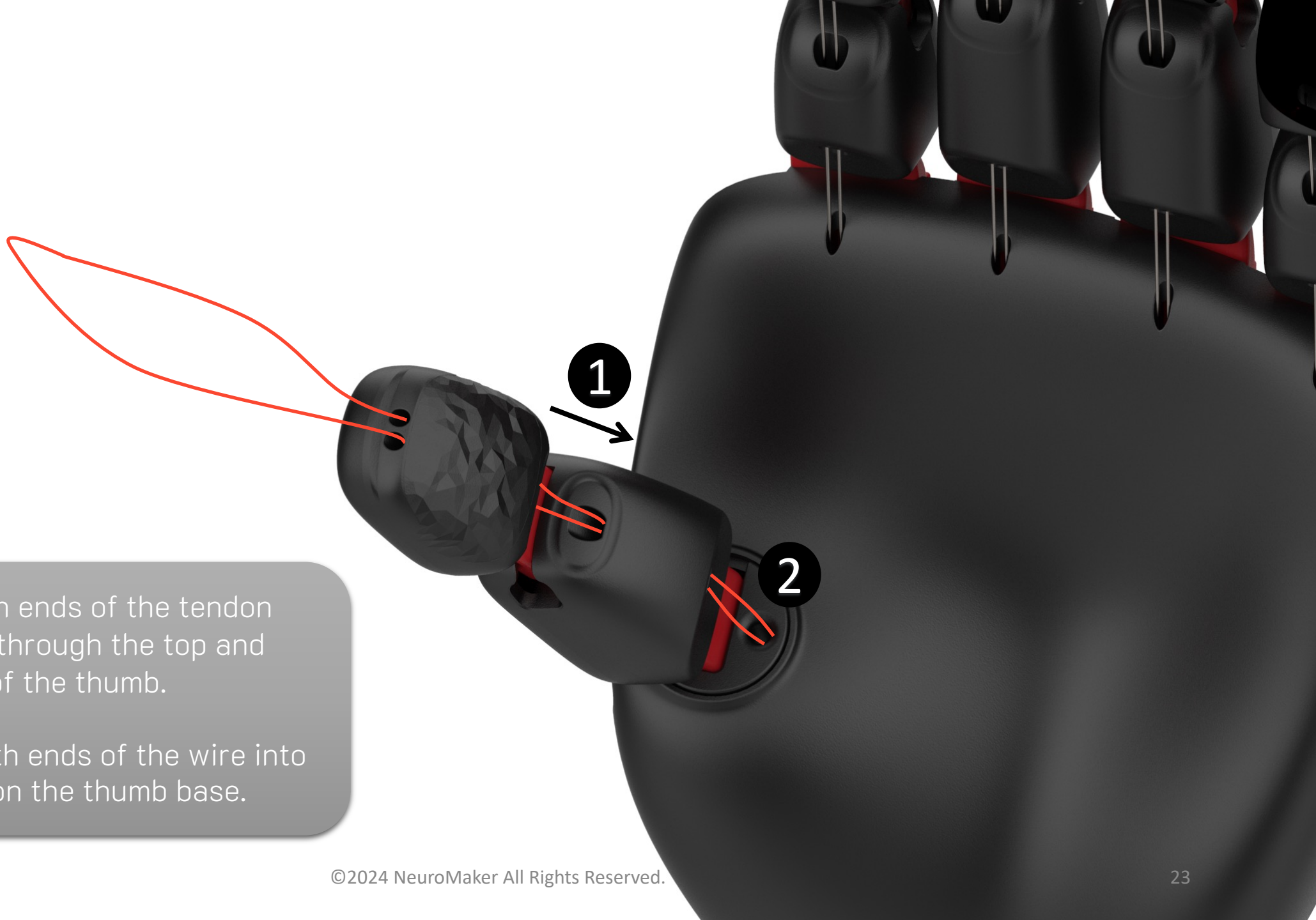

Step 1: Guide both ends of the tendon wire downwards through the top and middle sections of the thumb.

Step 2: Insert both ends of the wire into the slot located on the thumb base.



Pull the tendon wire downwards to tighten it, as shown in the illustration.





Guide the tendon wires through the holes marked 1-5 on the bottom side of the front palm.



Ensure exact holes depicted



Install the back palm.



Finished finger and palm assembly.



Install two servo motors  
on the servo board.

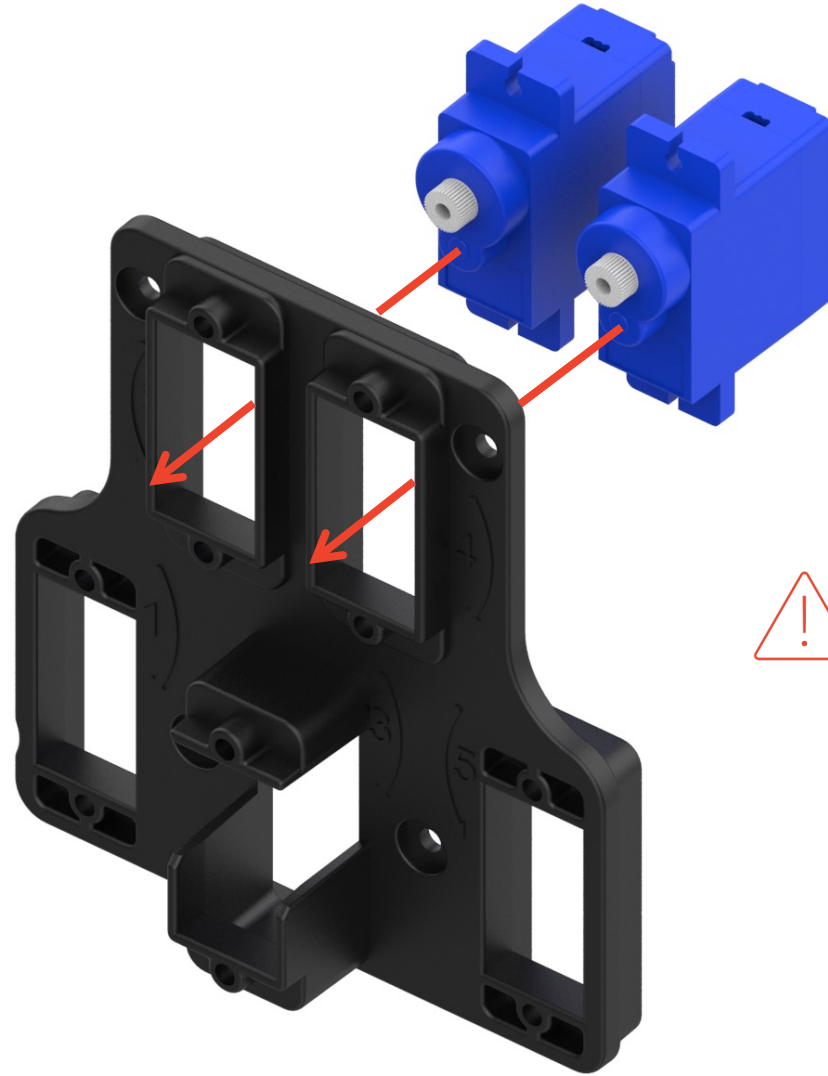

Ensure the orientation of  
the servo motors matches  
precisely with the depiction

Secure the top two servo motors.

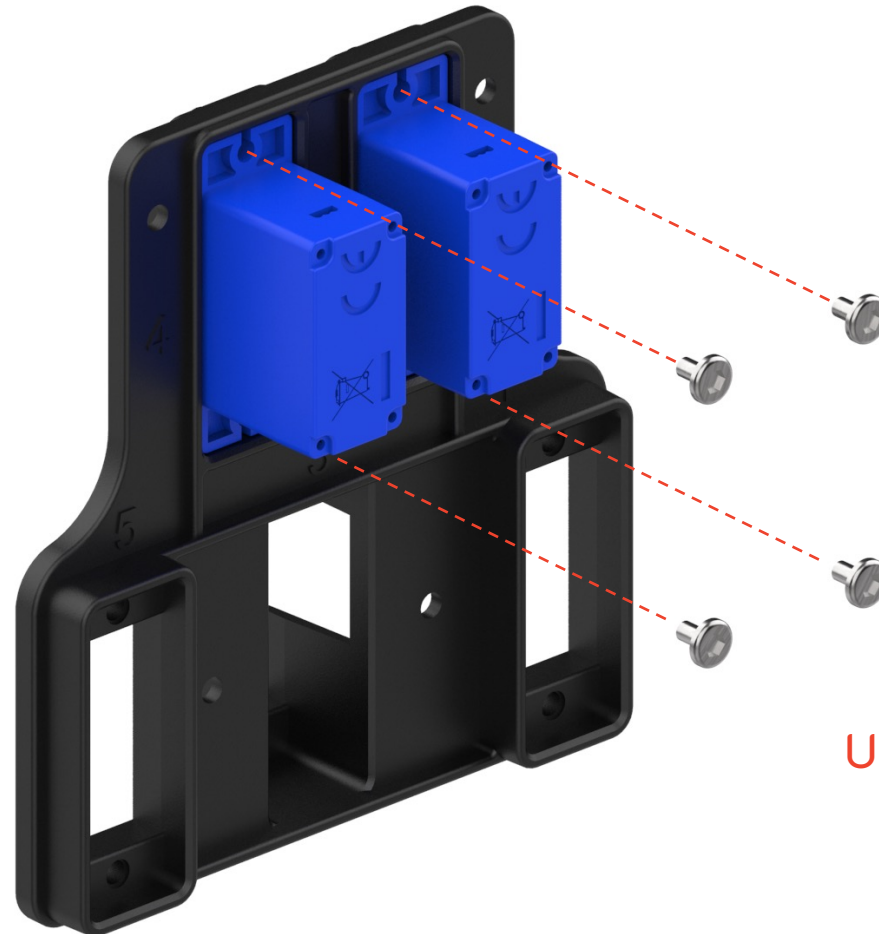

Use screw type **B**

Install three more servo motors on the servo board.

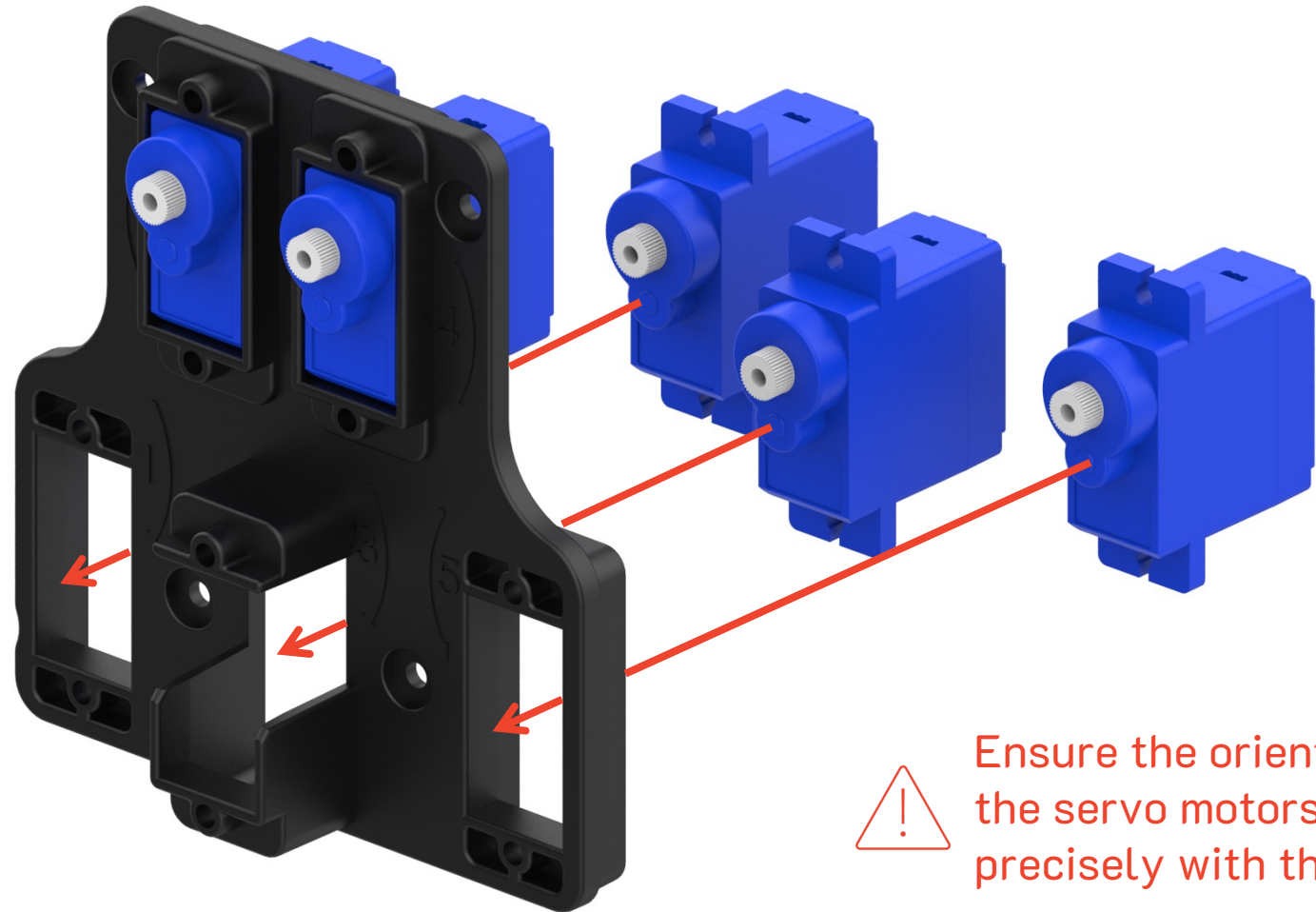

Secure the bottom three servo motors.

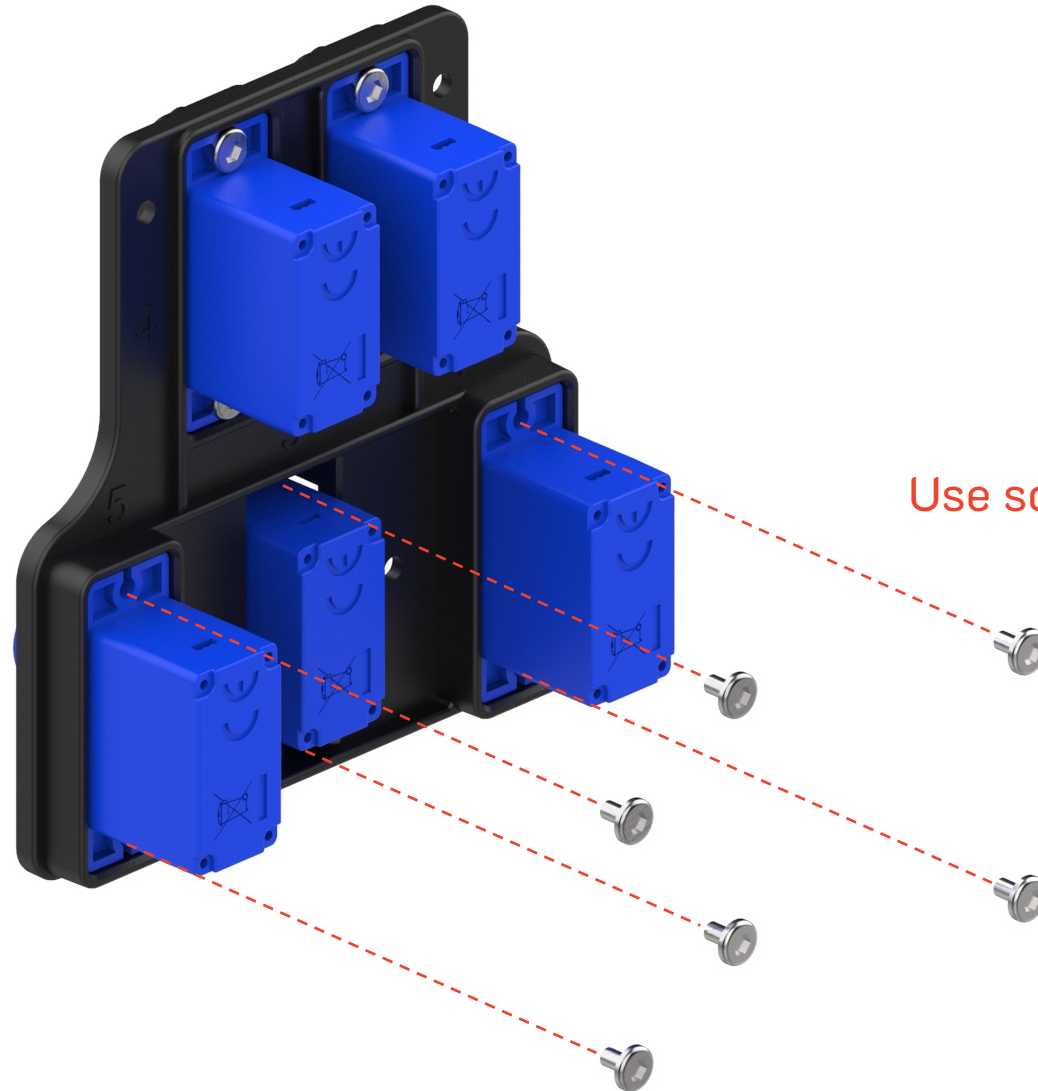



**NEUROMAKER**

Pay attention to the number markings on both the servo board and the back arm. **They will be used in the following steps.**

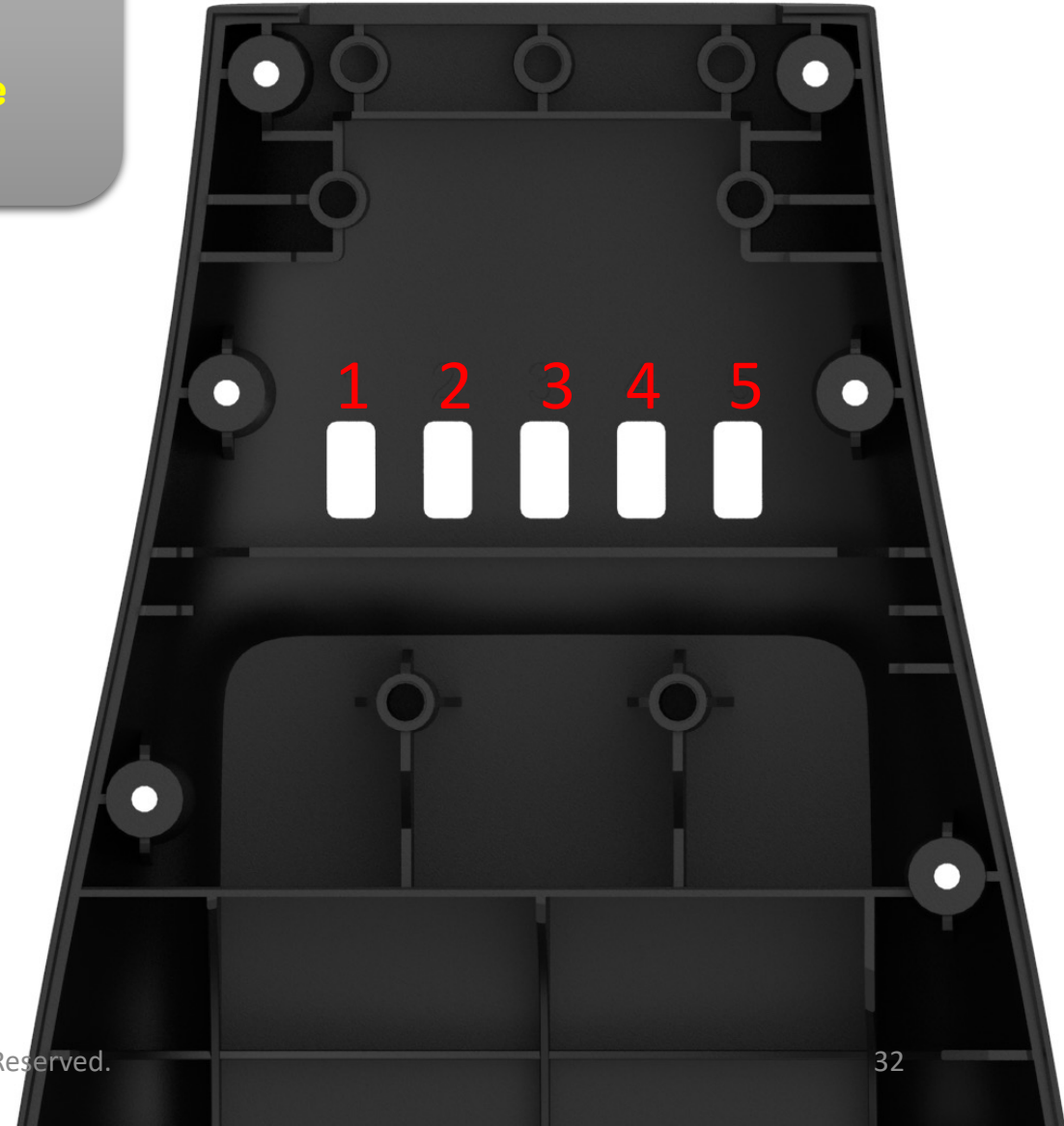
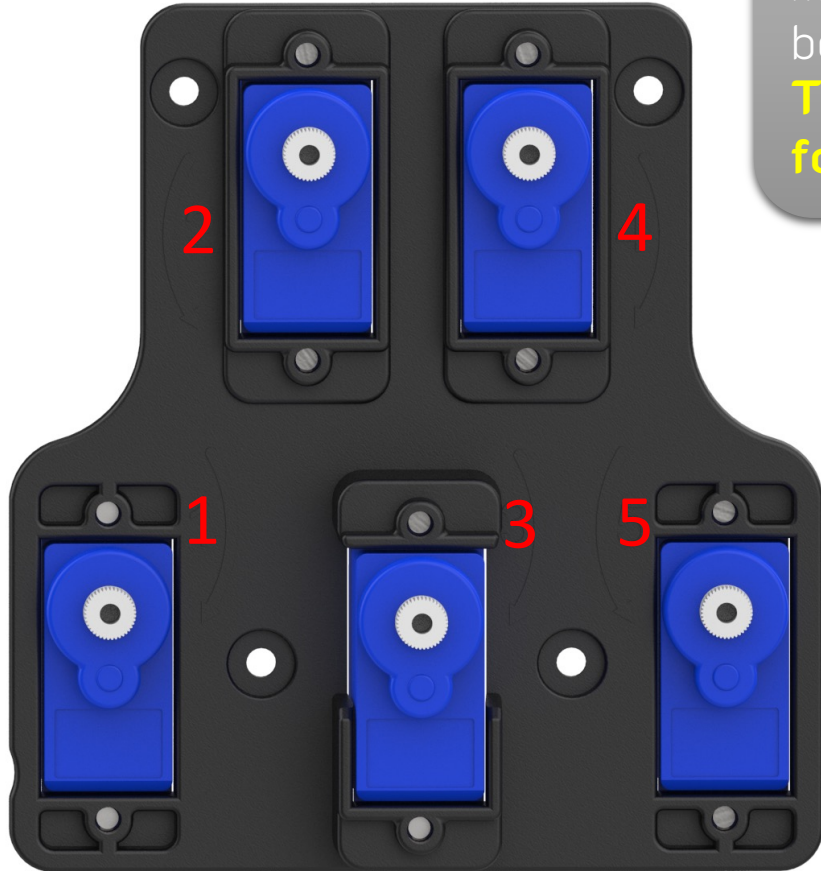



Bring the servo motor assembly close to the back arm.





**NEUROMAKER**

Guide the servo motor cables through the 5 holes on the back arm.

**Match the servo board numbers with the hole numbers. For example, cable from servo #1 goes through hole #1.**

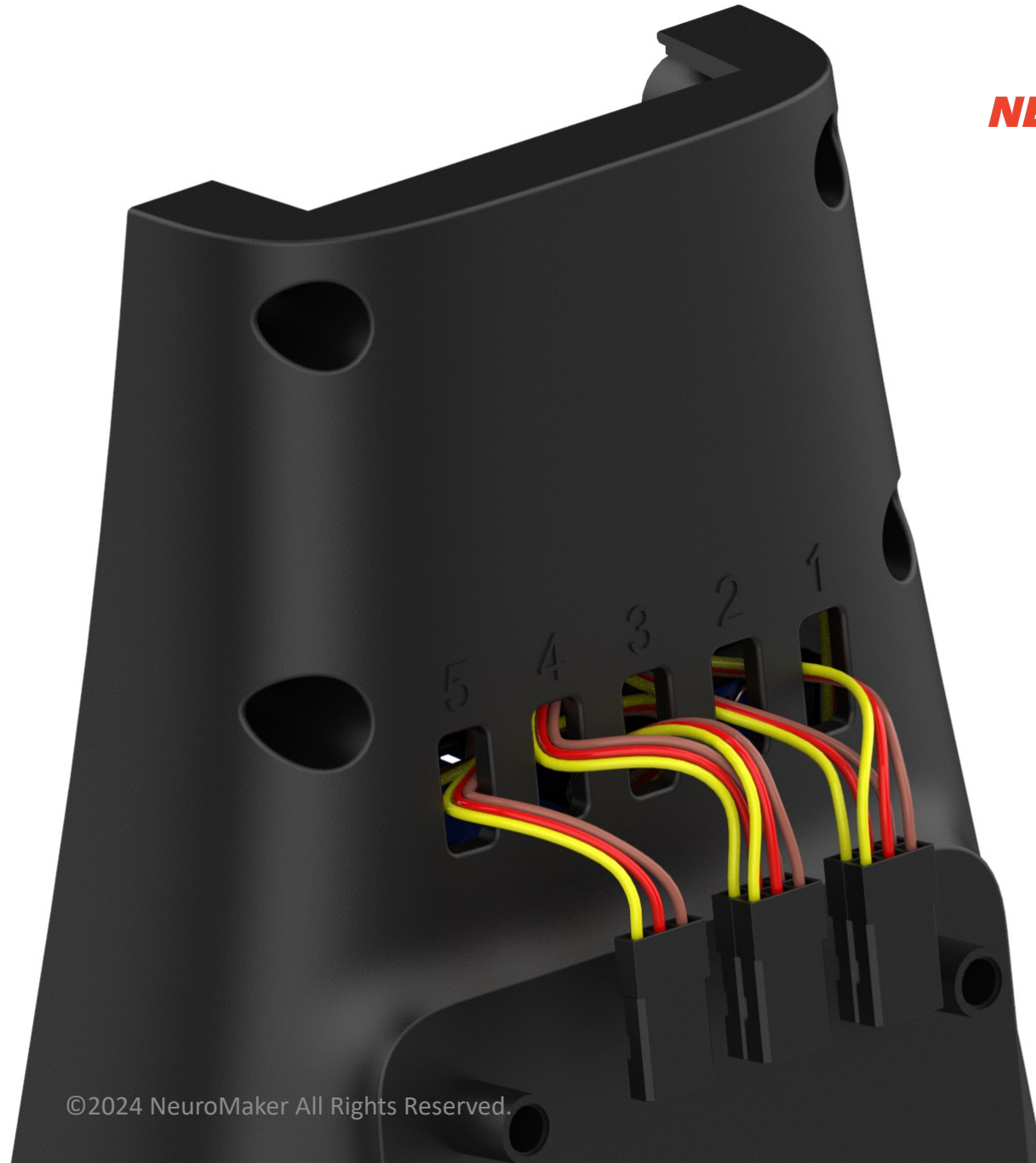

Install the servo board  
on the back arm.

Use screw type **C**

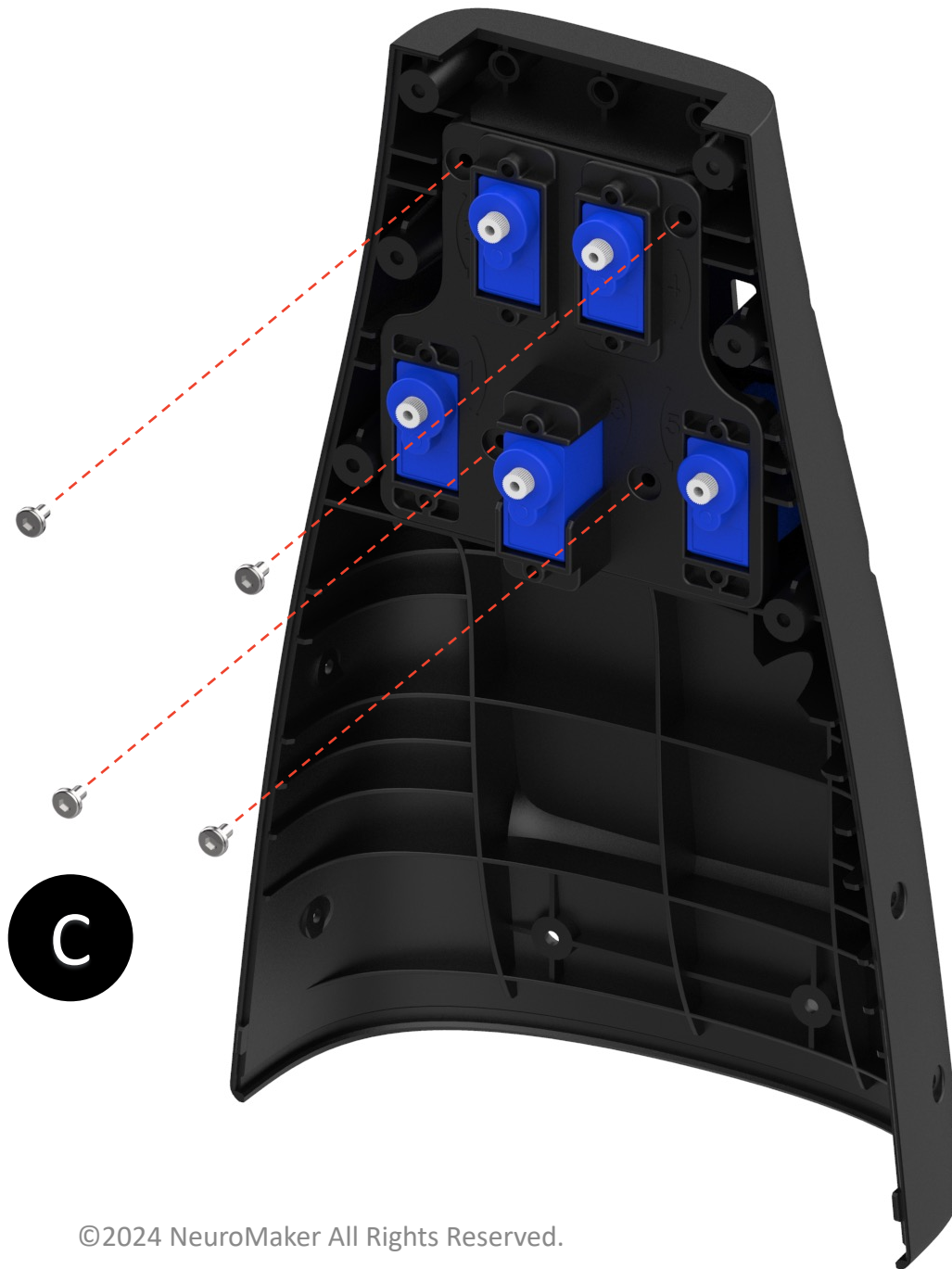

Install the NeuroMaker Core on the back arm.



Use screw type

**C**

Plug in the servo motor #2 to the **S2** port on the NeuroMaker Core.



Yellow wire must be on the left.  
Brown wire must be on the right.

Plug in the servo motor #1 to the **S1** port on the NeuroMaker Core.



Yellow wire must be on the left.  
Brown wire must be on the right.

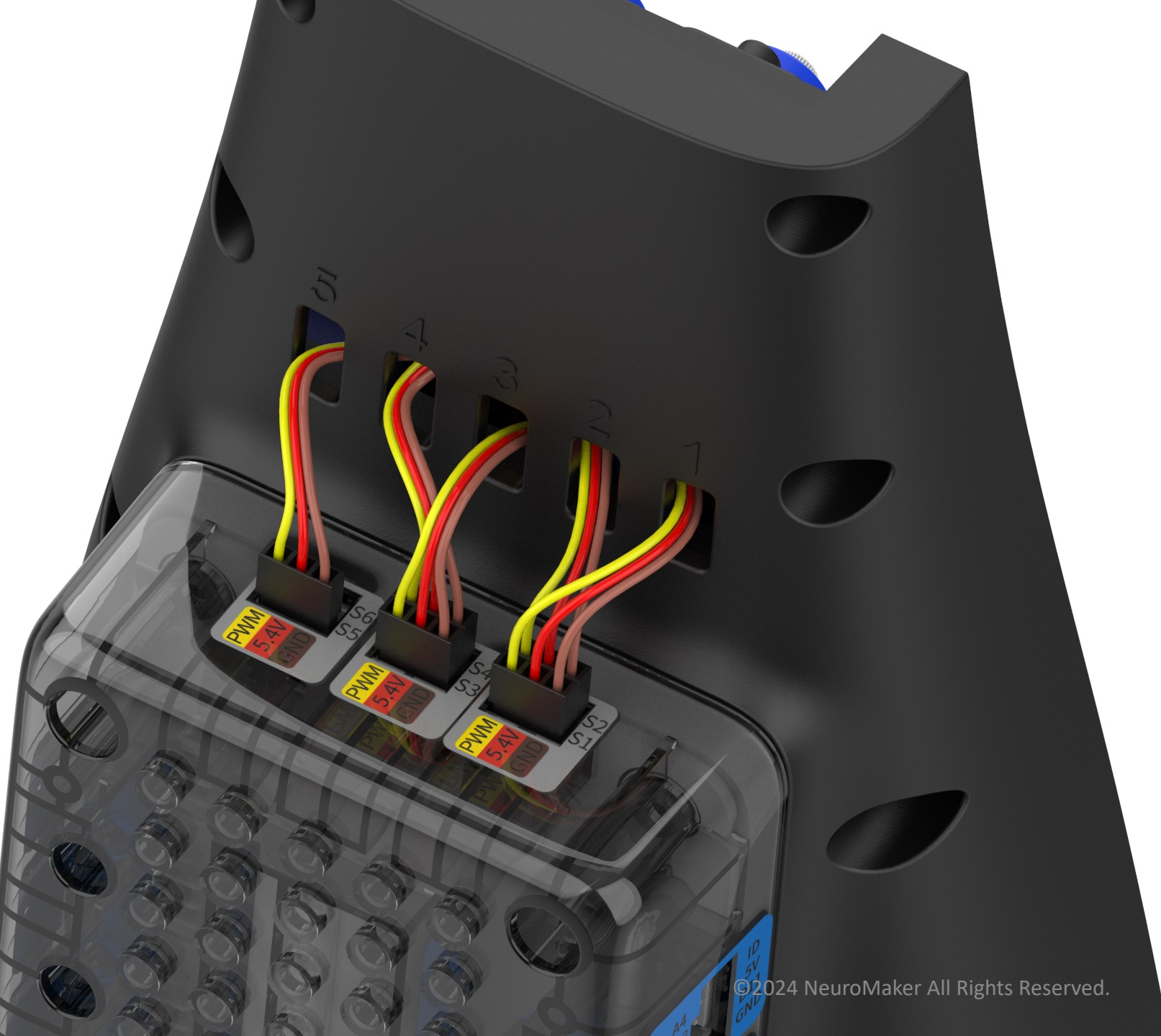

Following the same steps, plug in the cables from servo motors #4, #3 and #5.

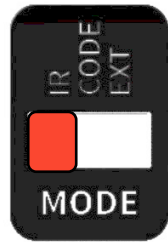

Step 1: Push the switch all the way to the left. Make sure it's under "IR".



Step 2: Press the power button to turn on the NeuroMaker Core.







**NEUROMAKER**

Install the servo arms on the servo motors in the illustration.  
**Make sure the arms are pointing straight up.**



Use screw type



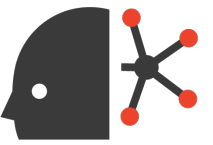

**NEUROMAKER**

Repeat the previous step for the remaining servo motors.

**Again, make sure the arms are pointing straight up.**



Use screw type





**NEURO**MAKER

Finished servo arm assembly.

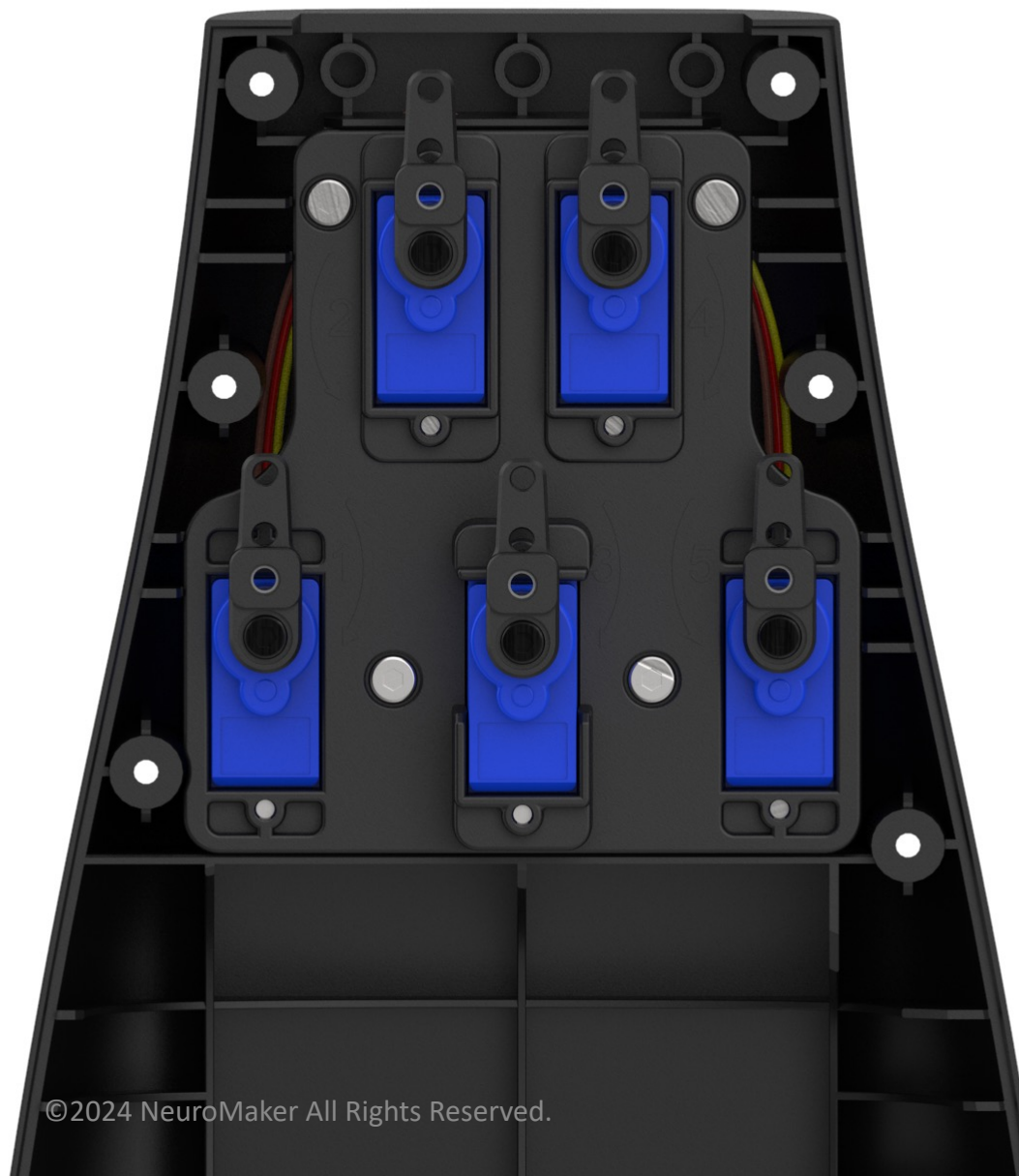

Assemble the hand assembly  
and the back arm assembly.

Use screw type

C

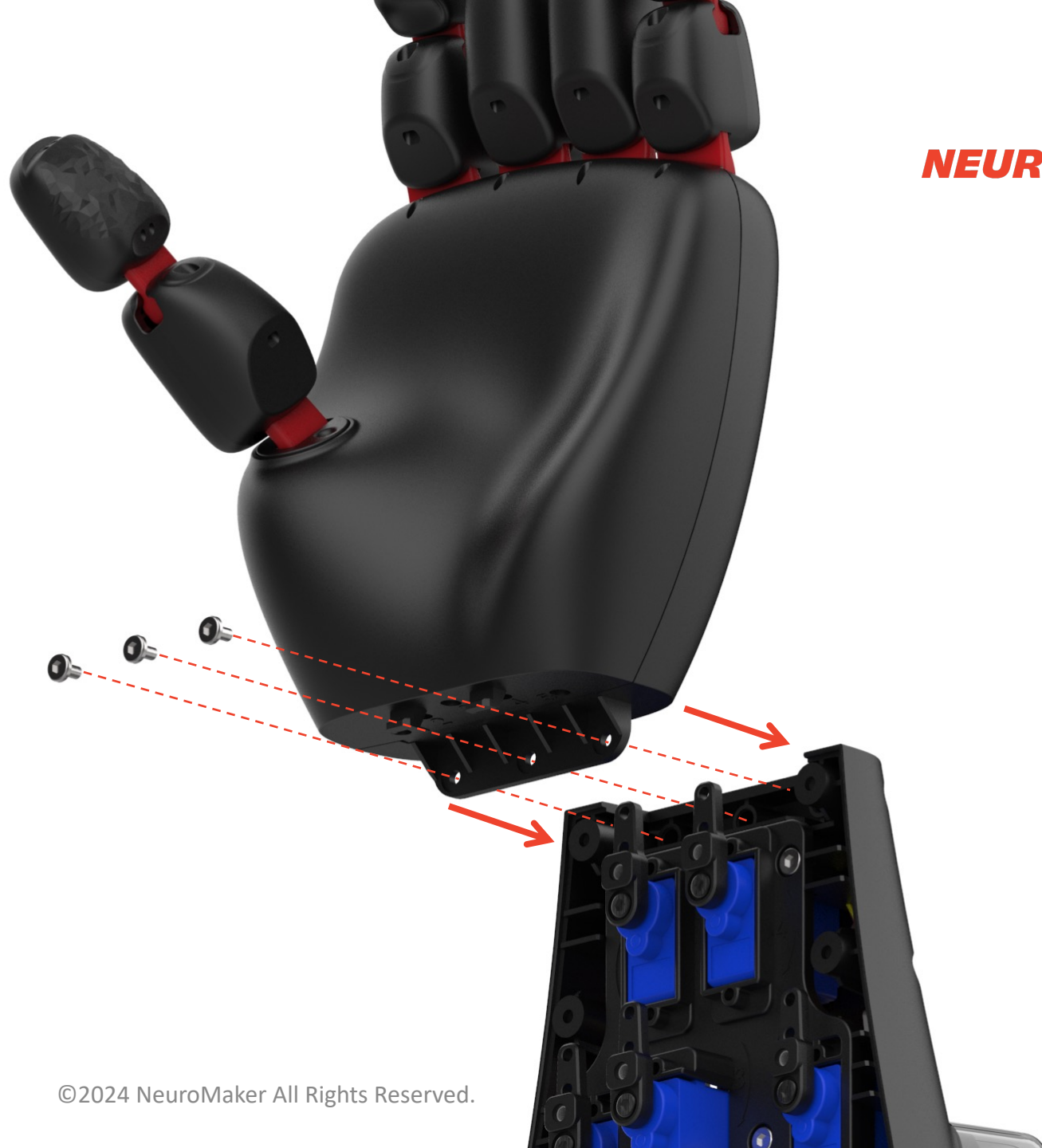

Finished servo arm assembly.





**NEUROMAKER**

Pay attention to the numbers on both the palm and the servo board.

In the upcoming steps, **it is crucial to connect each tendon wire to its corresponding servo motor.**

For instance, the tendon wire from hole #5 should be connected to servo #5.

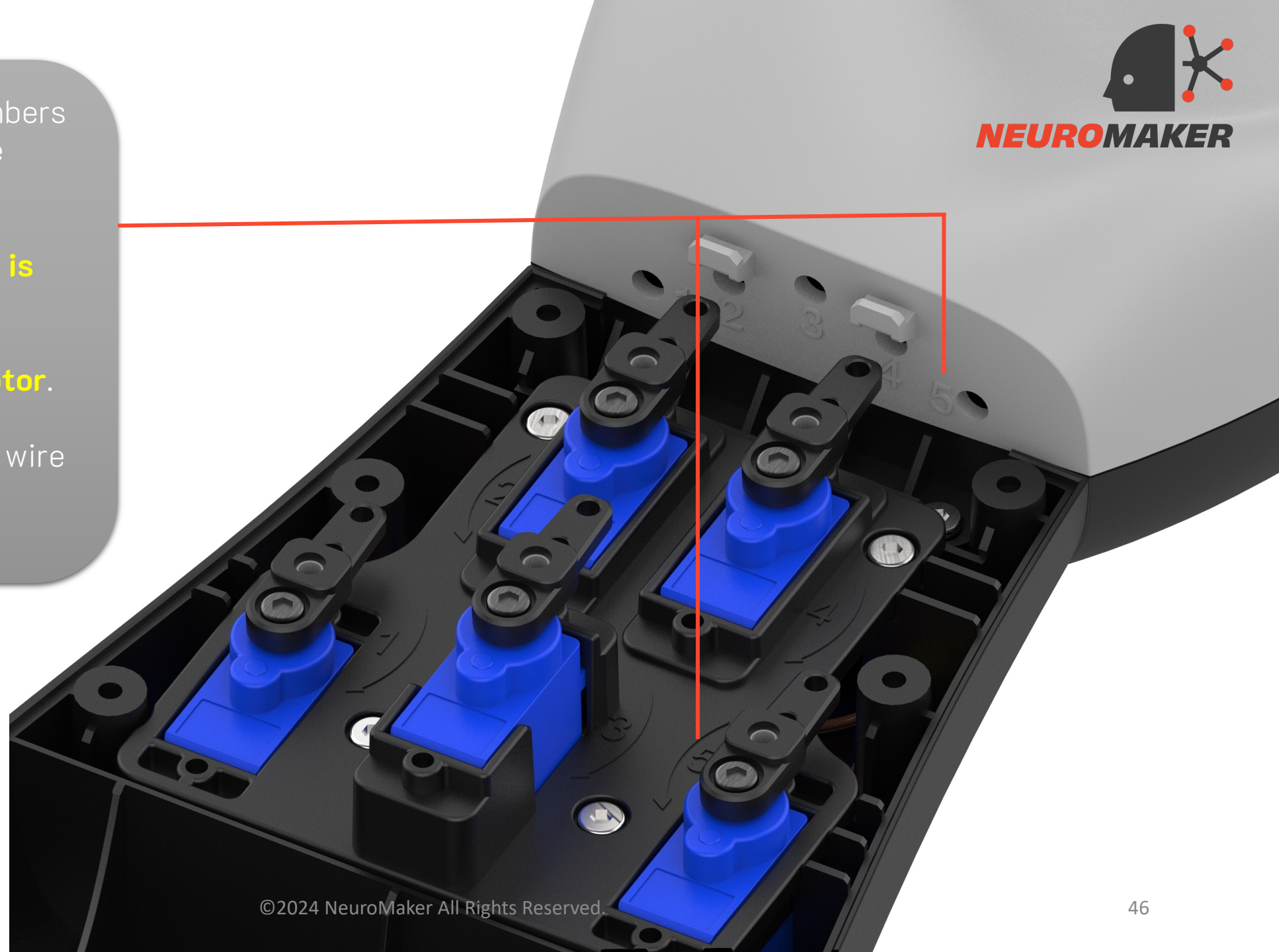



**NEUROMAKER**

Step 1: Gently pull the tendon wires and thread them through the **first hole** of the servo arm, starting from the underside and guiding them upwards, through to the top side.

Step 2: Take the wires and lead them through the **second hole**. This time, insert from the top side, pushing them downwards to emerge from the bottom.

Step 3: Draw the wire from the underside of the servo arm, threading them upwards to exit through the top side of the **third hole**.

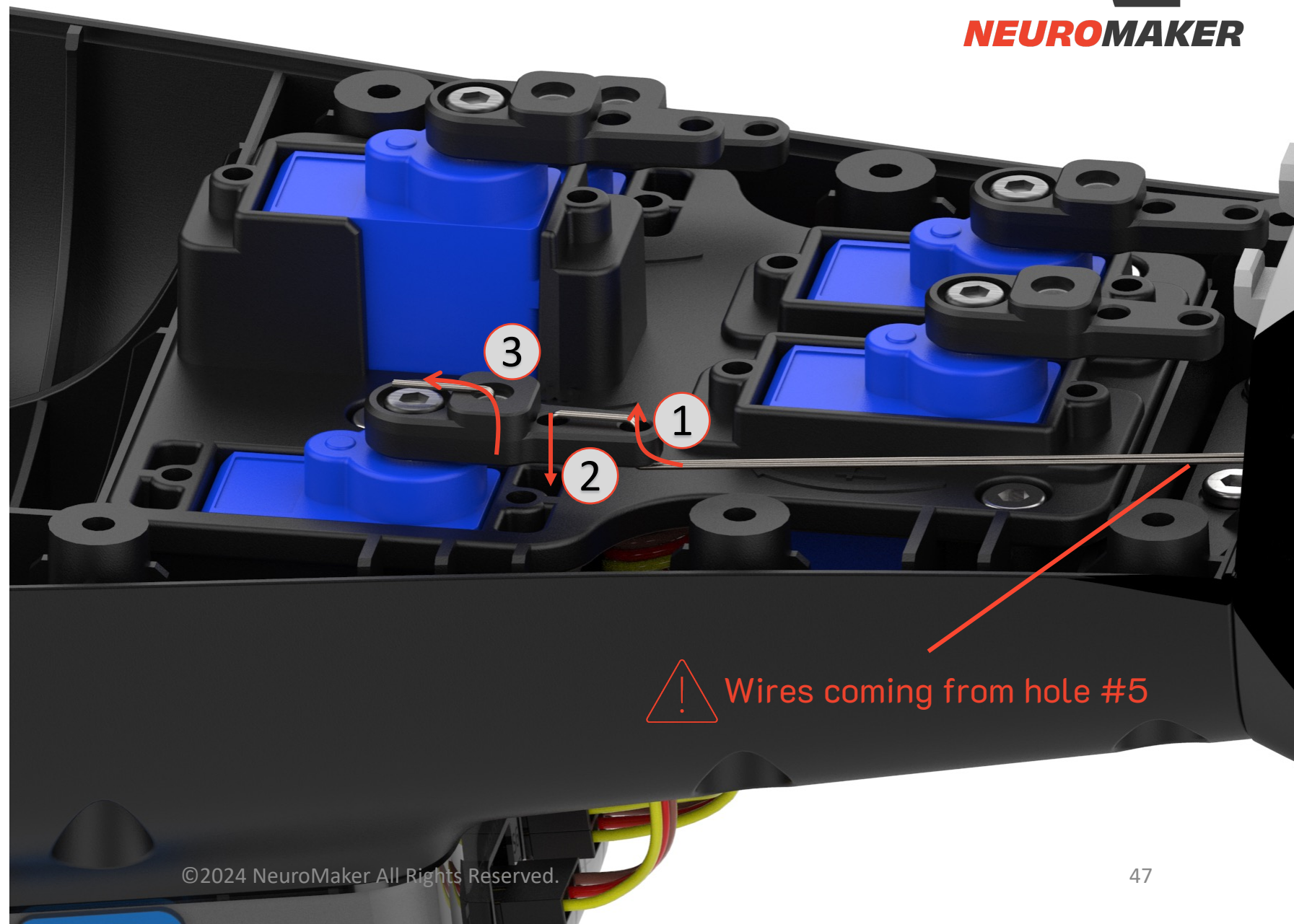

Wires coming from hole #5



**NEUROMAKER**

Utilize the screw to firmly secure the tendon wire in place.

As you tighten the screw, be vigilant to **maintain the finger in its natural, rested position.**

Use screw type







Repeat the same steps for servo motors #4 and #3.





Repeat the same steps for servo motors #2 and #1.





**NEUROMAKER**

Assemble the front arm and the arm insert.

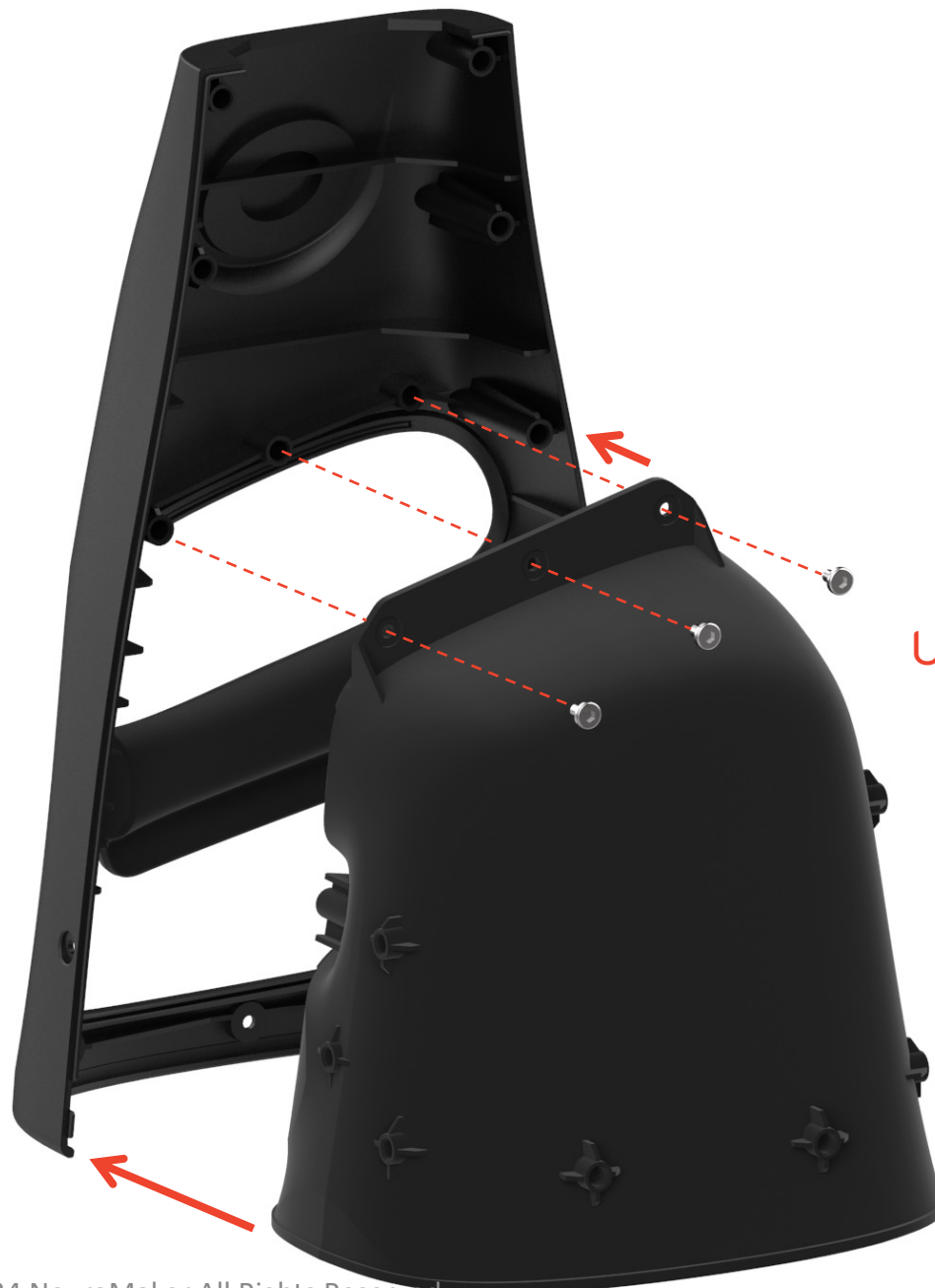

Use screw type **C**

Install screws to secure the front arm and the arm insert.

Use screw type

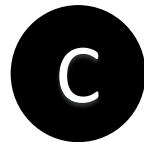

Assemble the front arm assembly with the main body.





**NEUROMAKER**

Install screws to secure two assemblies.



Use screw type

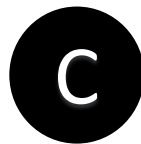



**NEUROMAKER**

Use screw type



Congratulations! Your  
NeuroMaker Hand is built.

Move on to the next page to  
start exploring!

